

INSTRUCTIONS

CLST93 INSTALLATION

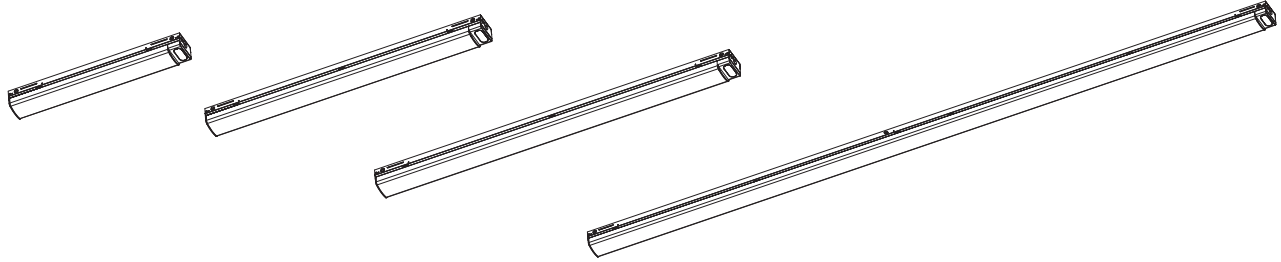

IMPORTANT

READ CAREFULLY BEFORE INSTALLING FIXTURE. RETAIN THESE INSTRUCTIONS FOR FUTURE REFERENCE.

The fixtures must be wired in accordance with the National Electrical Code and all applicable local codes. Proper grounding is required for safety. THIS PRODUCT MUST BE INSTALLED IN ACCORDANCE WITH THE APPLICABLE INSTALLATION CODE BY A PERSON FAMILIAR WITH THE CONSTRUCTION AND OPERATION OF THE PRODUCT AND THE HAZARDS INVOLVED.

WARNING: Disconnect or turn OFF power at the electrical panel before installing or maintaining fixture. No User serviceable parts inside fixture.

SURFACE MOUNTING

The fixture is suitable for indoor ceiling mounting, as follows:

1. Remove **Lens Tray Assembly** by pushing in/squeezing the **Fixtures Housing** sides (the point indicated by the arrow in Fig. 1) and lifting the **Lens Tray Assembly** to disengage.

CAUTION: The Lens Tray Assembly may drop out quickly.

Lens Tray Assembly is supported with (2) **Tether Cables** (Fig. 3).

2. Attach both **Junction Box Cover Plates** to the **Fixture Housing** by sliding in the direction of arrows as shown in Fig. 2. Secure with (2) **Screws** (provided).
3. Feed supply wires through **Wire Access Hole**. Securely mount the **Fixture Housing** directly to a sturdy surface using the correct mounting hardware through the **Drill Locations** (2) Fig.1. The **Junction Box Cover Plates** is used to cover the Junction Box. (Fig. 3).
4. Make electrical connections as shown in wiring diagram (Fig. 7) . Use approved wiring connectors and wire to local NEC codes. Push all wires back into **Fixture Housing**. Be careful not to pinch wires.
5. Snap **Lens Tray Assembly** back into **Fixture Housing** and remove protective plastic from **Lens Tray Assembly**.

WARNING: To prevent wiring damage or abrasion, do not expose wiring to sharp objects.

Fig: 1

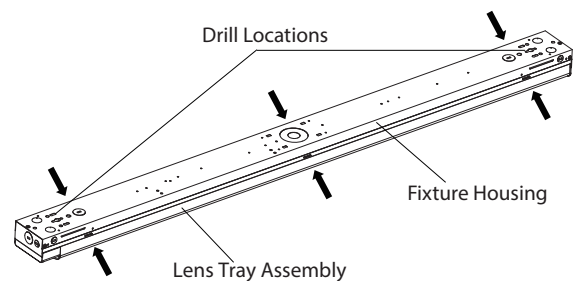

Fig: 2

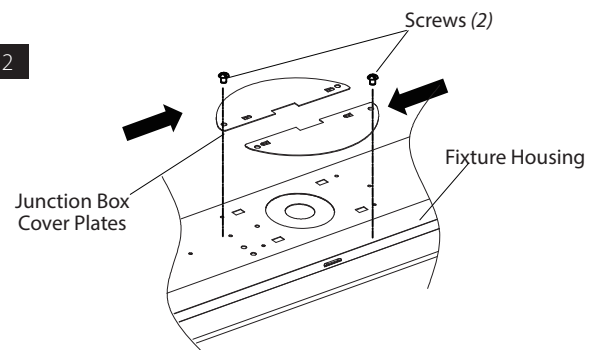
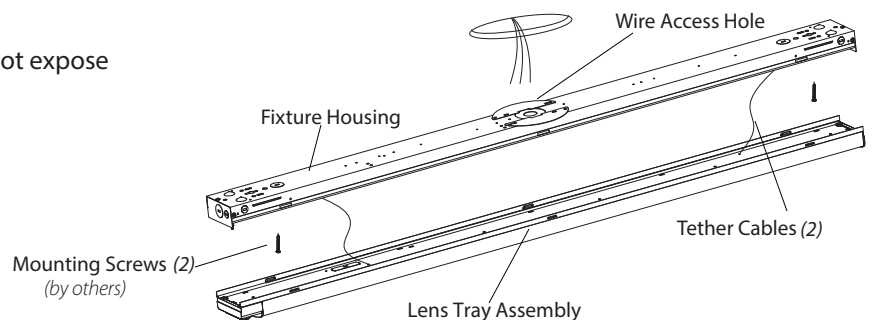

Fig: 3



INSTRUCTIONS

CLST93 INSTALLATION



V-HOOK / CHAIN MOUNTING

1. Loop the **V-Hooks** into the **Mounting Slots** to each end of the **Fixture Housing** as shown in Fig. 4.
2. Connect the **Chains** to the mounting surface and hang the **Fixture** from **V-Hooks** as shown in Fig. 5.
3. Fixture mounting height and spacing should be determined by application requirements. **V-Hook** and **Chain** is suitable to support four (4) times the weight of the Fixture.
4. Make electrical connections as shown in wiring diagram (Fig. 7). Use approved wiring connectors and suitable conduit (not provided). Wire to local NEC codes. Push all wires back into **Fixture Housing**. Be careful not to pinch wires.

WARNING: To prevent wiring damage or abrasion, do not expose wiring to sharp objects.

Fig: 4

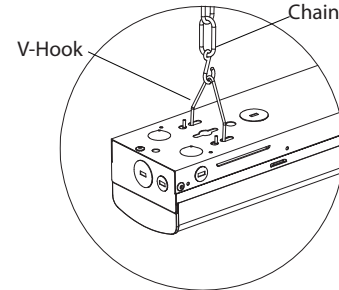
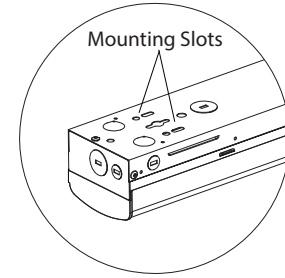
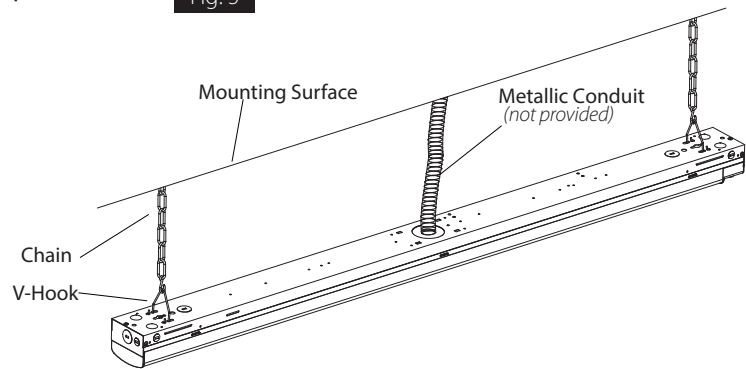

Fig: 5



FIELD ADJUSTMENT

Follow instructions below to change the **Fixture Power (W)** and/or **Color Temperature (CCT)** from factory settings:

Factory Settings:

2FT	25/20/15W	25W / 4000K
3FT	30/25/20W	40W / 4000K
4FT	50/40/30W	40W / 4000K
8FT	70/85/100W	100W / 4000K

1. Locate the **Field Adjustable Switches** on the driver inside the **Fixture Housing** as shown in Fig. 6.
2. Select **Power (W)** and **Color Temperature (CCT)** by sliding respective switch to the desired value (Fig. 6).

Fig: 6

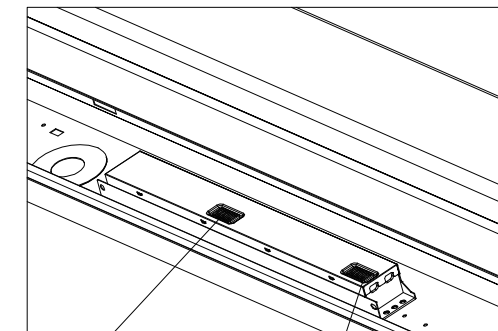

Power (W)

Color Temperature (CCT)

INSTRUCTIONS

CLST93 INSTALLATION



0-10V DIMMABLE WIRING

Universal voltage driver permits operation at 120V thru 277V, 50 or 60 Hz. For 0-10V Dimming, follow the wiring directions in Fig. 7.

1. Connect the black fixture lead to the LINE supply lead.
2. Connect the white fixture lead to the COMMON supply lead.
3. Connect the GROUND wire from fixture to supply ground.
4. Connect the purple fixture lead to the (V+) DIM lead.
5. Connect the pink fixture lead to the (V-) DIM lead.
6. Cap the yellow fixture lead, if present. (use with sensor)

Fig. 7

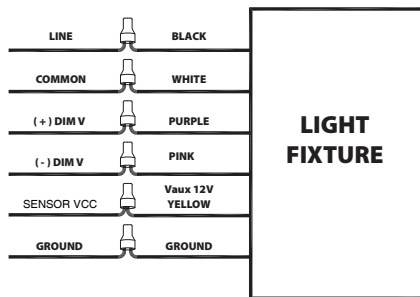

SENSOR OPTIONAL

1. Lift the **Cover Plate** up from the gap at one end with a suitable tool, and remove the wire from the clamp of the **Cover Plate** as shown in Fig. 6.
2. Connect wires as shown in wiring diagram (Fig. 5). then press the sensor into the corresponding slot, and confirm it is securely secured.

Fig: 8

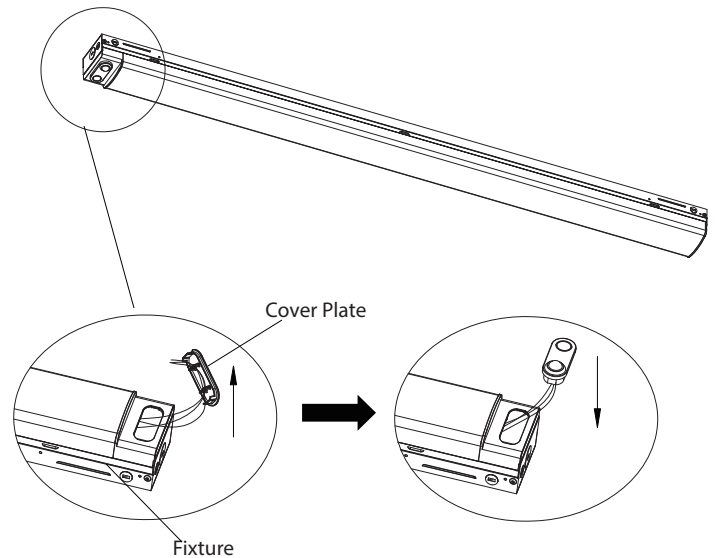

CLEANING

CAUTION: Be sure fixture temperature is cool enough to touch. Do not clean or maintain while fixture is energized.

1. Clean polystyrene lens & fixture with non-abrasive cleaning solution.
2. Do not open fixture to clean the LEDs. Do not touch the LEDs.

WIRE GUARDS OPTIONAL

1. Insert the provided **Clips** (4) onto the wire guards.
2. Fasten the **Clips** by drilling screws into the prepunched holes of fixture body. (Fig. 9).

Fig: 9

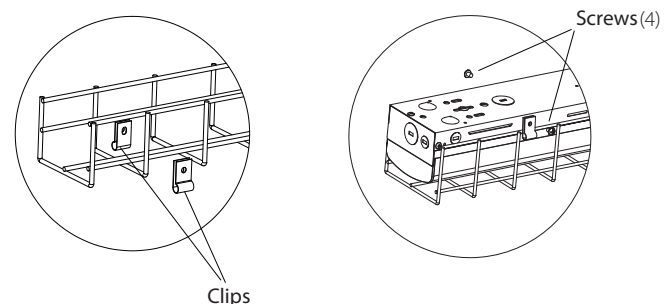
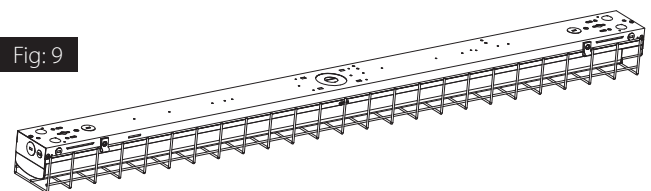

TROUBLESHOOTING

1. Check the line voltage at fixture. Refer to wiring directions.
2. Is the fixture grounded properly?

INSTRUCTIONS

CLST93 INSTALLATION



EMERGENCY BATTERY MODELS

WIRING

NOTE: Make sure that the necessary branch circuit wiring is available. An **UNSWITCHED** AC source of power is required. The emergency driver must be fed from the same branch circuit as the LED driver.

1. Connect **UNSWITCHED HOT** fixture lead to **HOT AC** supply line.
2. If using an **UNSWITCHED** circuit, connect **UNSWITCHED** and **SWITCHED** lines together.
3. If using a **SWITCHED** circuit, connect **SWITCHED HOT** AC fixture lead to the external.
4. For 0-10V dimming connect **DIM (+)** purple and **DIM (-)** pink leads to dimming circuit.
5. After installation is complete supply AC power to the fixture and connect the **BATTERY**.
6. When power is on the fixture should be on and the Charging Indicator Light should illuminate to indicate the battery is charging.
7. Once the **BATTERY** has charged for at least one hour a short duration test may be performed by pressing the test button.
8. After the battery has charged for 24 hours a long duration test

OPERATION

1. When AC power is applied, the charging indicator light is illuminated, indicating that the **BATTERY** is being charged.
2. When power fails, the standby power automatically switches to emergency power (*internal battery*), operating at reduced illumination.
3. When AC power is restored, the emergency driver automatically returns to charging mode.

MAINTENANCE

Although no routine maintenance is required to keep the emergency driver functional, it should be checked periodically to ensure that it is working. The following schedule is recommended:

1. Visually inspect the charging indicator light monthly. It should be illuminated.
2. Test the emergency operation of the fixture at 30-day intervals for a minimum of 30 seconds.
3. Conduct a 90-minute discharge test once a year. Fixture will operate at reduced illumination for a minimum of 90 minutes.

FIG.10

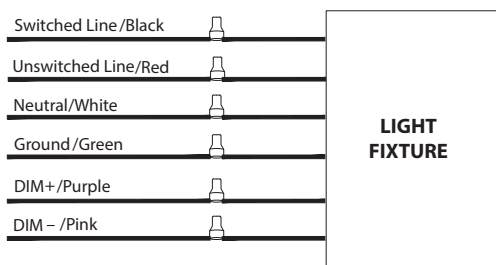

TROUBLESHOOTING

1. Be sure the fixture is grounded properly.
2. If the charging indicator light does not illuminate after pressing and releasing the **Test Button** (Fig. 11), check power and check if battery is connected properly.

FIG.11

